



## Cost effective refilling of activated carbon filter

The →leachate from a landfill in North Rhine-Westphalia, Germany, used to be transported by road tanker to the nearest sewage treatment plant. Since 1998 a →biological treatment plant has been in operation, which has now handled more than 650,000 m<sup>3</sup> of leachate, at a maximum rate of 350 m<sup>3</sup>/day. Four activated carbon filters, each filled with 20 m<sup>3</sup>, handle the residual COD load. The wastewater is fed into them in a sequence that depends on how long the activated carbon has been in use. A freshly regenerated filter discharges treated →wastewater with a COD concentration of about 50 mg/l; this is well below the →limit of 400 mg/l and is therefore a major cost factor. This can be avoided with the help of the →COD cuvette test.

**Author:** Uwe Karg

- Dipl. Ing. Water technology
- In charge of process products at HACH LANGE
- Technical specialist for sewage treatment plants and drinking water treatment



**LANGE** 

# Measure COD, improve processes



Fig 1: The degradation performance of the activated carbon filters is determined with the LANGE COD cuvette test

## TECHNICAL DATA

### Leachate treatment

Start-up: 1998

Design capacity: max. 350 m<sup>3</sup>/d

### Process technology:

Biological treatment with nitrification/denitrification, addition of methanol and phosphoric acid, aeration with compressed air (3 bar) and, when necessary, additional pure oxygen, ultrafiltration, activated carbon treatment

### Limit values/Outflow (mg/l):

COD	400 / 350-380
Nitrite	240 / 5
Nitrate	10 / < 1
NH <sub>4</sub> -N	100 / ~ 0,1
AOX	0,5 / 0,2-0,3

- Determination of COD degradation performance
- Targeted monitoring of outflow values
- Exact scheduling of regeneration
- Wastewater is fed into the filters in the correct sequence

### Landfill leachate: The treatment is controlled via COD level

Landfill leachate is characterised by high organic loads together with water soluble nitrates, sulphates, chlorides and heavy metals. The harmful substances profile depends on the type of waste, the weather and biochemical degradation processes.

The substances washed out of the buried waste are responsible for a COD of up to 2,500 mg/l. They always consist of poorly degradable carbon compounds. A biological wastewater treatment system therefore needs additional readily degradable carbon compounds (methanol) and phosphoric acids in the absence of a supply of phosphorus.

### Biological treatment in two stages

Figure 2 shows the individual stages of the process: A receiver (5) enables the collected leachate to be fed uniformly into the upstream denitrification step (6). For the nitrate to be degraded here, readily degradable carbon compounds (methanol), which are not present in the leachate, have to be added. The two connected nitrification zones (7 and 8) then have the task of reducing the COD from 2,500 mg/l to about 1,000 mg/l and reducing the ammonium content from 1,200 mg/l to 0 mg/l.

To keep the resulting high nitrate concentration in check, a continuous stream is internally recycled from the nitrification stage into the denitrification tanks.

- 1 Inflow
- 2 Aeration
- 3 Ultrafiltration
- 4 Raw leachate tanks
- 5 Receiver
- 6 Denitrification
- 7 Nitrification 1
- 8 Nitrification 2
- 9 Activated carbon treatment (1-4)
- 10 Outflow
- 11 COD sampling location

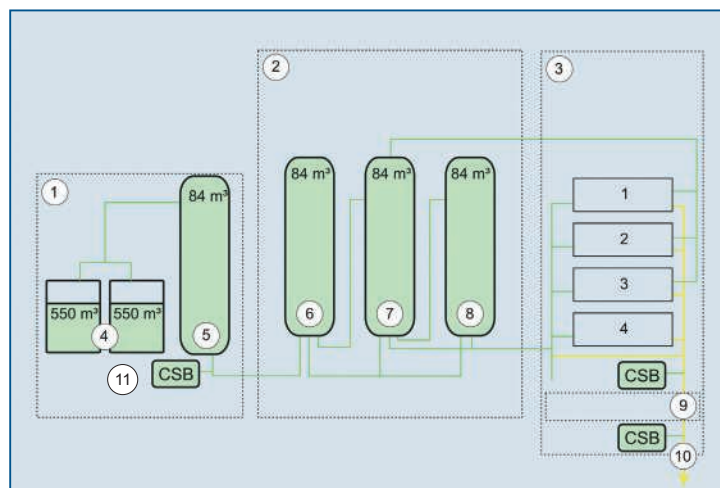

Fig. 2: Leachate treatment process steps



Fig. 3: Ultrafiltration – space-saving and fast



Fig. 4: Cut open view of the tube module of the ultrafiltration system: space saving solids separation

A positive pressure of 3 bar improves oxygen solubility in the two aerated tanks. Should the continuously monitored ammonium content in the outflow nevertheless exceed 3 mg/l, pure oxygen is automatically injected into both tanks in order to boost nitrification.

### Ultrafiltration system

At the end of the biological treatment stage, an ultrafiltration system (Fig. 3) with filter areas of 3 x 40 m<sup>2</sup> and 1 x 55 m<sup>2</sup> extracts the bacteria. They are fed back into the denitrification stage. In contrast to a sedimentation tank, ultrafiltration removes the solids quickly, fully independent of the settling properties of undissolved substances.

### Activated carbon filtration

The treated and ultrafiltered leachate proceeds towards the activated carbon filtration stage (Fig. 5): 4 x 26 m<sup>3</sup> in size, series-connected, each with a content of 20 m<sup>3</sup> of activated carbon.

The water stream flows through the highly active and extremely absorbent hollow granules, shedding its content of dissolved substances. This process is so efficient that outflow concentrations of 50 mg/l COD (instead of 350-380 mg/l) would be achievable. This is considerable additional cost due to the frequent regeneration of the activated carbon.

However, LANGE cuvette tests for COD ensure reliable daily compliance with the limit value of 400 mg/l, so that no additional costs are incurred for uneconomic refilling of the individual activated carbon filters.

- 1 Inflow from ultrafiltration
- 2 Vent pipe
- 3 COD sampling location

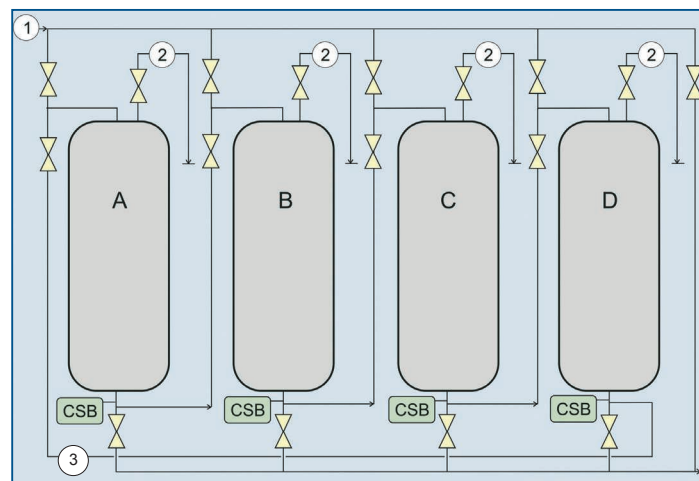

Fig. 5: Activated carbon filtration; 4 Filters (A, B, C, D), each with 20 m<sup>3</sup> activated carbon

## Cost effective analysis: Annual savings of £ 17,000/€ 25,000

The COD is measured in the inflow and outflow of the biological treatment stage. In the outflow of each individual activated carbon filter and in the total outflow of the plant – every day, 5 days per week, in the operator's own laboratory (Fig. 6), with LANGE COD cuvette tests and a DR 2800 spectrophotometer. A high-temperature thermostat helps to reduce the digestion time to a minimum.

### Cuvette tests make analysis simple

Ready to use and predosed reagents for COD chromosulphuric acid and mercury sulphate. The closed cuvette test system guarantees maximum safety – for the analyst and the surroundings. This simple handling excludes error sources from the very beginning.



Fig. 6: As well as COD, LANGE cuvette tests determine NH<sub>4</sub>, AOX, NO<sub>3</sub>, NO<sub>2</sub>, PO<sub>4</sub>, N tot in leachate

### Payback assured: More efficient refilling of the filters

The results of the COD measurements provide information about the performance of the total plant and each individual activated carbon filter. It is then easy to calculate how much water should be fed through which filter, and when water can be discharged from the third filter to be mixed with the outflow from the fourth filter to give a total outflow with a COD of 350-380 mg/l. This multi-stream solution extends the period between successive regenerations of an activated carbon filter, thus cutting filter costs by 10-15% or approximately £ 17,000/€ 25,000 per year.

### HACH LANGE Services



Contact us to place an order, request information or receive technical support.



On site technical support.



[www.hach-lange.com](http://www.hach-lange.com) up to date and secure, with downloads, information and e-shop.



Service packages and extended warranty up to 5 years.



Regular customer information by post and email.

### Efficiency-improving cuvette tests and measuring instruments

DESCRIPTION	MEASURING RANGE	ART. NO.
COD cuvette test	100-2,000 mg/l 50-300 mg/l	LCK514 LCK614
<b>Additional cuvette tests:</b>		
<b>Ammonium</b>	47-130 mg/l NH <sub>4</sub> -N 1-12 mg/l NH <sub>4</sub> -N	LCK302 LCK305
<b>AOX</b>	0.005-0.5 mg/l	LCK391
<b>Nitrogen, total, LATON</b>	20-100 mg/l TN <sub>b</sub>	LCK338
<b>Nitrate</b>	0.23-13.5 mg/l NO <sub>3</sub> -N; 1-60 mg/l NO <sub>3</sub>	LCK339
<b>Nitrite</b>	0.015-0.6 mg/l NO <sub>2</sub> -N; 0.05-2 mg/l NO <sub>2</sub>	LCK341
	0.6-6 mg/l NO <sub>2</sub> -N; 2-20 mg/l NO <sub>2</sub>	LCK342
<b>Phosphate</b>	0.5-5 mg/l PO <sub>4</sub> -P; 1.5-15 mg/l PO <sub>4</sub>	LCK348
<b>DR 2800 spectrophotometer</b> for 200 pre-programmed tests, 50 user methods and storage capacity for 500 measured values		LPV422. 99.00001
<b>High-temperature HT 200 S thermostat</b> High efficient digestions at 170°C for COD within 35 minutes		LTV077

Table 1: Cuvette tests and laboratory equipment

HACH LANGE NV/SA  
Motstraat 54  
B-2800 Mechelen  
Tel. +32 (0)15 423500  
Fax +32 (0)15 416120  
info@hach-lange.be  
www.hach-lange.be



Tel. +32 (0)15 42 35 00



**LANGE**